

WEATHERGUARD SITE

IP65 NON-CORROSIVE FITTINGS

Weatherguard Site offers the very latest in IP65 non-corrosive site lighting. High efficiency 100 lm/W LEDs and stainless steel clips as standard, plus LEDs and drivers that can easily be replaced at the end of life, for minimum environmental impact.

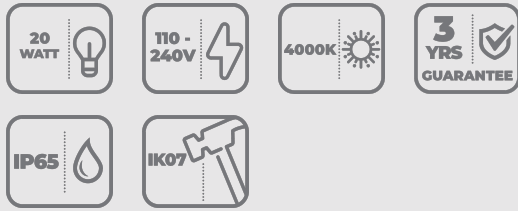

Features

- Unique, future proof replaceable LED modules
- Durable IP65 & IK07 body and diffuser
- High efficacy - 100 lm/W
- Emergency versions available



Specification

Code	Description	Lumen Output	Emergency Lumen Output	Wattage	Efficacy
WGS220Y	Weatherguard Site 600mm	2000 lm		20W	100 lm/W

Product Information

Guarantee	3 Years
Colour Appearance (CCT)	4000K
IP Rating	IP65
IK Rating	IK07
Voltage	110V
Material (Body/Housing)	Polycarbonate
Material (Diffuser/Cover)	Polycarbonate
Colour Rendition (CRI)	Ra > 80

Colour Finish	Yellow
LED Life Expectancy	L80B50 30,000 Hours
Power Factor	0.5
Frequency	50/60Hz
Driver Type	Fixed Output
Approval	UKCA & CE
Electrical Class	Class I
Working Temperature	-25°C to 40°C



WEATHERGUARD SITE

IP65 NON-CORROSIVE FITTINGS

Packaging Information

Dimensions (mm)	L: 664 x W: 103 x D: 78 mm
Product Net Weight (kg)	0.78 kg
Barcode	5055807621199
Box Dimensions (mm)	L: 650 x W: 105 x D: 80 mm
Box Gross Weight (kg)	0.87 kg

Units/Outer Carton	8
Outer Carton Barcode	15055807621196
Outer Carton Dimensions (mm)	L: 690 x W: 335 x D: 225 mm
Outer Carton Gross Weight (kg)	7.25 kg

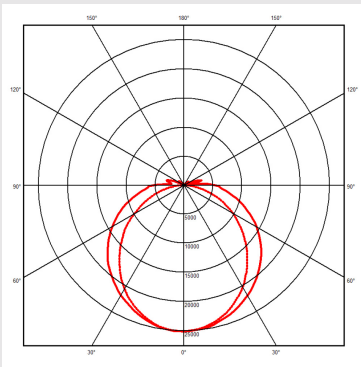
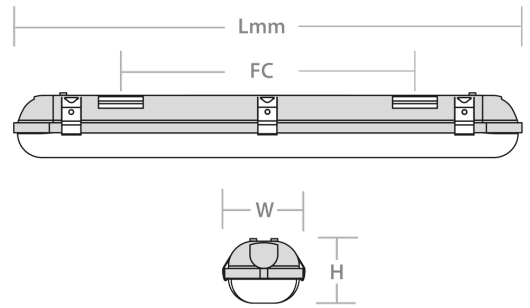

ENERGY
Red Arrow
 WGS

A
 B
 C
 D
 E
F
 G

20-50
 kWh/1000h